

**SPECIAL UNITS ARE NON-RETURNABLE
 *AVAILABLE AT ADDITIONAL COSTS

ALL TERRAIN PALLET TRUCK, ALL-T-2

REV. A, 1-23-09 SR
 REV. B, 4-06-10 PE

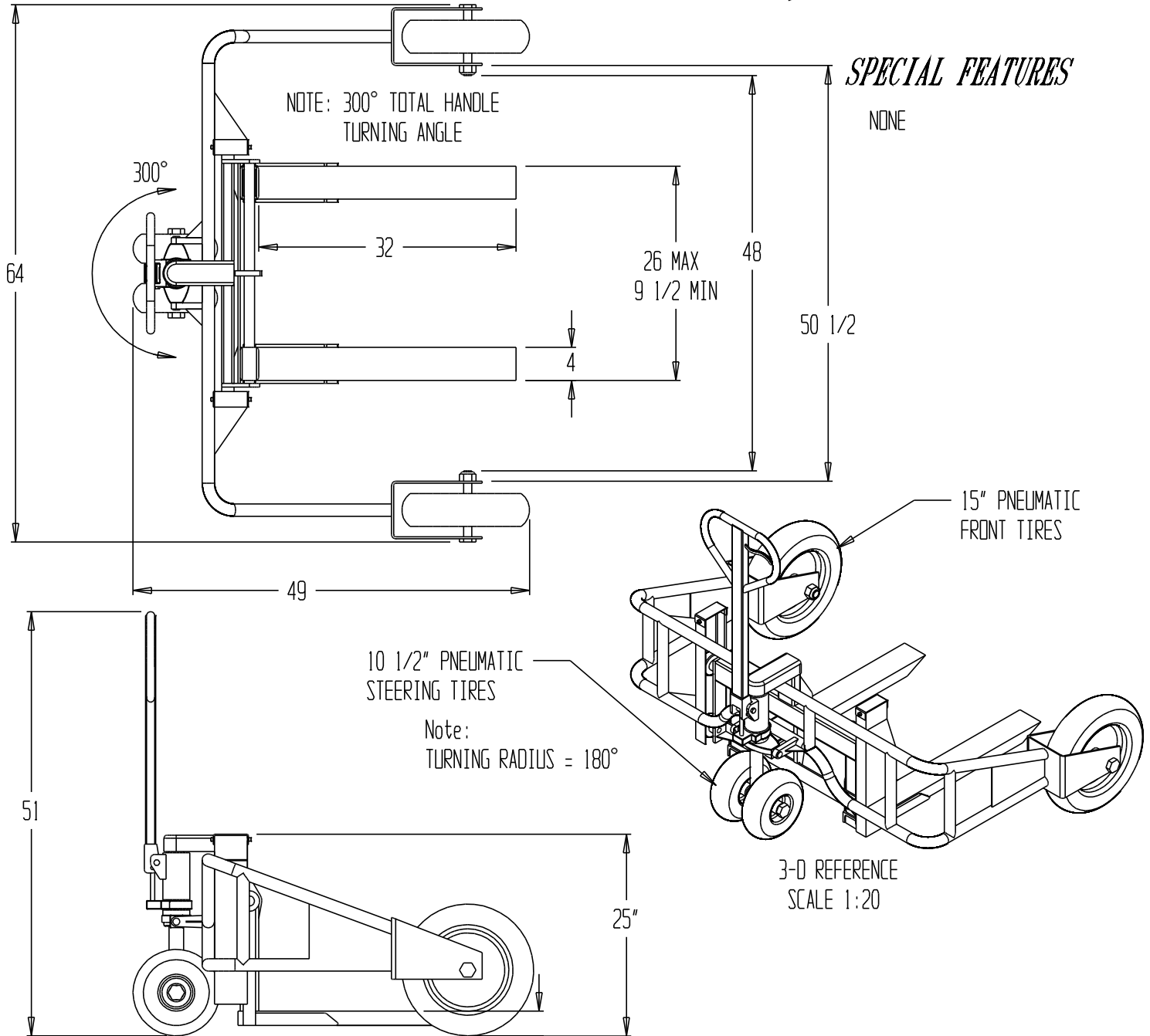

SPECIAL FEATURES

NONE

STANDARD FEATURES

MODEL NUMBER: ALL-T-2
 CAPACITY: 2,000 LB. AT 12" HORIZONTAL LOAD CENTER
 1,500 LB. AT 15" HORIZONTAL LOAD CENTER
 1,000 LB. AT 24" HORIZONTAL LOAD CENTER
 (FOR USE WITH 48" LG PALLET)

OVERALL WIDTH: 63 3/4"
 OVERALL LENGTH: 49"
 OVERALL HEIGHT: 51"
 OVERALL FORK WIDTH: 9 1/2" TO 26"
 FORK LENGTH: 32"
 FORK LOWERED HEIGHT: 3 1/8"
 FORK RAISED HEIGHT: 9"
 INDIVIDUAL FORK WIDTH: 4"
 STRADDLE I.D.: 50 1/2"

3 1/8 LOWERED
 9 RAISED

DIMENSION TOLERANCE +/- 1/2"

**A
P
P
R
O
V
A
L** I, THE UNDERSIGNED, AGREE THAT THE PRODUCT AS REPRESENTED SATISFIES DESIGN & DIMENSION REQUIREMENTS. I ALSO ACKNOWLEDGE MY DUTY TO CONFIRM PRODUCT & INSTALLATION COMPLIANCE WITH ALL APPLICABLE FEDERAL, STATE AND LOCAL REGULATIONS & STANDARDS.
ALL SPECIAL UNITS ARE NON-RETURNABLE
 As drawn As marked
 Signed: _____ Date: _____
 LEAD TIME WILL START UPON RECEIPT OF SIGNED APPROVAL DRAWING

FOR INTERNAL USE ONLY PROJECT SIGN OFF	
SALES	
ENG	
FAB.	
POWER	

DISTRIBUTOR'S NAME: VESTIL MFG		P.O.#: -
DRAWN BY: S. ROSE		DATE: 6/1/2004
REFERENCE: -	SCALE: -	SALES: -
QUOTED LEADTIME: -	QUOTE #: -	DRWG./FILE NAME: ALL-T-2